

Name: JOHN BERNARD JR.

Date:

Event: CLUB RACE

Track Conditions: Outdoor  Indoor  Wet  Dry  High Bite  Low Bite   
 Rough  Smooth  Hard Packed  Loose/Loamy  Blue Groove

Bumpsteer/Ackerman/Servo Saver:

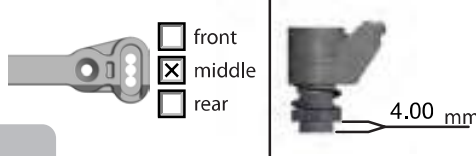

### Front End:

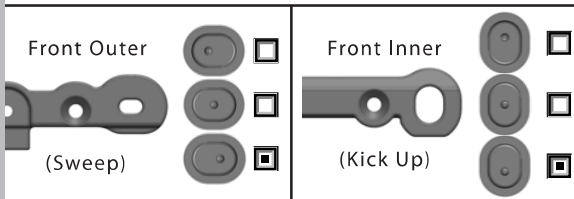
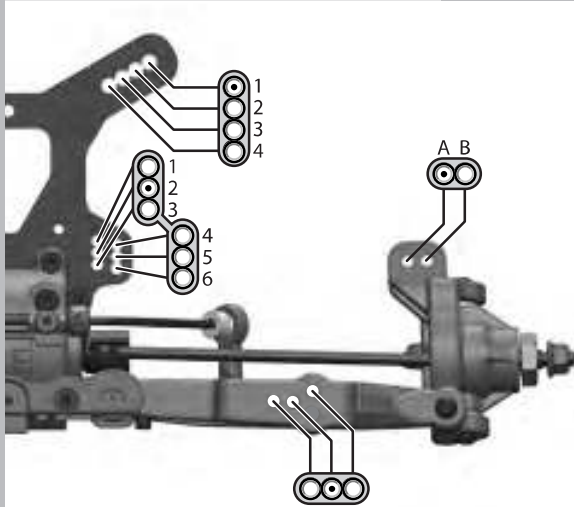

### Rear End:

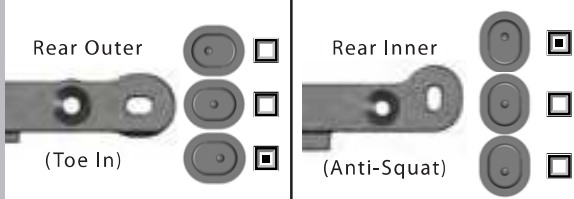
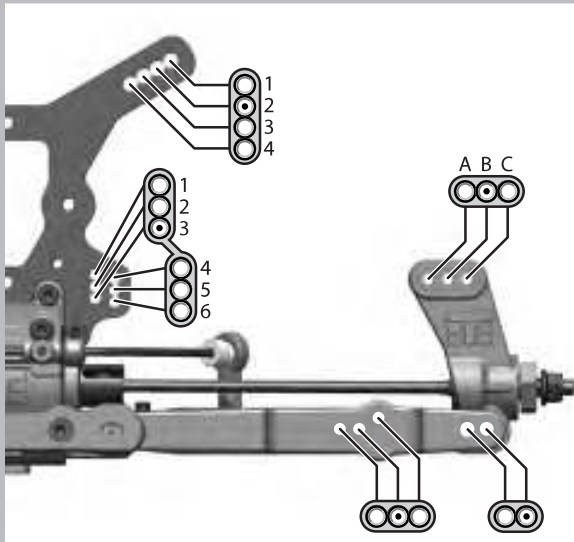

### Suspension:

	FRONT	REAR
RIDE HEIGHT	26mm	25mm
CAMBER	-1°	-1°
TOE (in/out)	0°	4.5°
SWAY BAR	2.4mm	2.4mm
SHOCK LENGTH (DROOP)	102mm	122mm

### Body/Mounts:

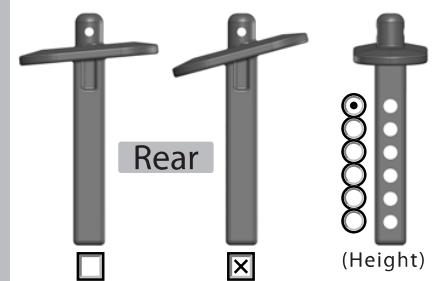
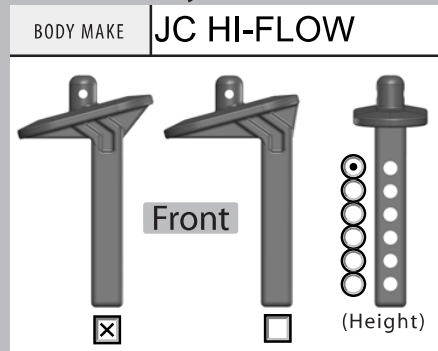

### Wheelbase:

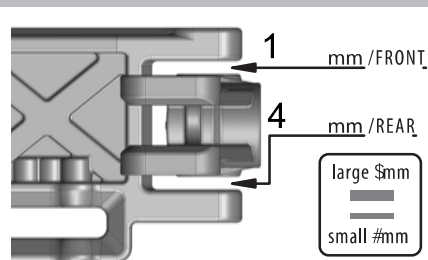

### Shocks:

	FRONT	REAR
OIL	AE 35	AE 30
PISTON	8 X 1.3	8 X 1.3
SPRING	PINK	GREEN
REBOUND	25 %	25 %
STD/EMUL/VENT	STD	STD

### Tires / Wheels:

	FRONT	REAR
BRAND/TREAD	JC 3D'S	JC 3D'S
COMPOUND	GREEN	GREEN
INSERT	STD	STD
WHEEL	HAZARD	HAZARD

NOTES: +1MM HEXES

### Differential Oil:

FRONT	CENTER	REAR
7	7	3

### Electronics:

ESC:	XERUN SCT PRO
Battery:	STING 7200/90
Motor:	REVTECH 4800
Radio:	RADIOPOST
Servo:	SAVOX 1258

### Drivetrain:

SPUR GEAR	Metal <input type="checkbox"/> Composite <input checked="" type="checkbox"/>
Traktion Drive	<input type="checkbox"/> Elektri-Clutch <input type="checkbox"/> Pinion <input checked="" type="checkbox"/>
PINION SIZE	14 (teeth)
Mechanical Brakes	<input type="checkbox"/> Motor Brakes <input checked="" type="checkbox"/>

### Chassis Braces:

Front <input checked="" type="checkbox"/>	Middle <input type="checkbox"/>	Rear <input type="checkbox"/>
(front brace is always recommended)		

### Notes:

**NO TIMING, HW MOTOR HEATSINK/FAN**